

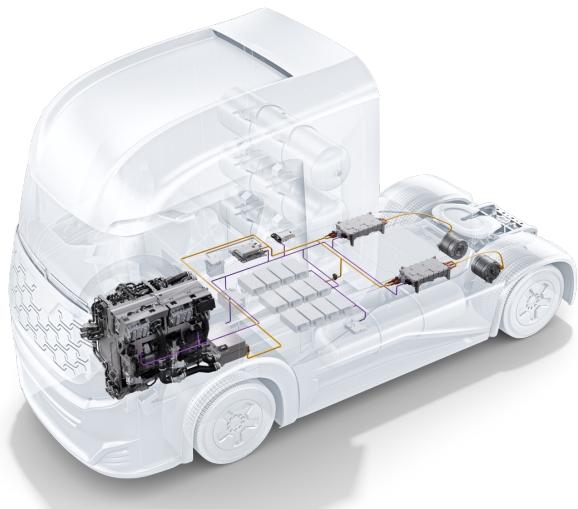

Energy

Fuel cell power module twinbox

Highly integrated and compact system solution for fuel cell-electric commercial vehicles

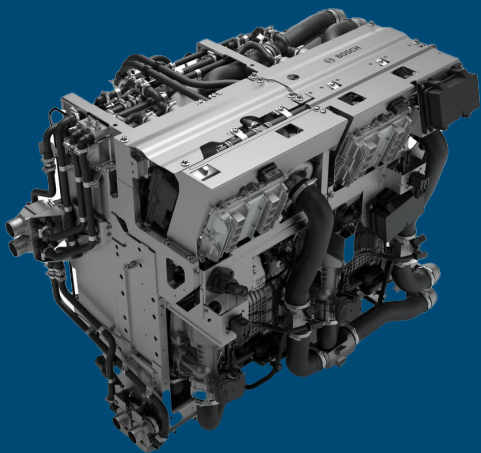

Advanced technology

that contributes to climate-neutral mobility

Compact design

Highly integrated system solution for fuel cell-electric commercial vehicles

- Combines the fuel cell stack, as well as the subsystems for the hydrogen and air supplies, the cooling circuit, and current supply in one module
- Scalable solution thanks to modular design
- Driven by time to market first fuel cell system for heavy commercial vehicles in series production
- Due to robust design and durability, the fuel cell power module is particularly well suited to commercial vehicles' requirements
- Bosch supplies the entire fuel cell system from a single source